

Clutcher®

U.S. Patent No. 7,222,824



Cable Hanging System

Labor-saving, versatile means for hanging static load HVAC Systems

- Meets SMACNA upper and lower attachment construction standards if used per manufacturer's installation guidelines
- Comprehensive Clutcher Hanging System Load Charts and Installation Videos available online at Ductmate.com
- Seismic tested and conforms to ICC Code guidelines EG284
- Engineered for strength and durability
- Tapered bore design for fast and easy installation
- Eliminates the need to stock multiple lengths of cable
- Compact design is aesthetically pleasing
- Easily adjust hanging height by hand
- Available in 3 sizes to meet specific load ranges
- Items can be hung at angles up to 60° from vertical

IMPORTANT INFORMATION

Before use or installation of product, read and follow all product information and warnings. Do not use product in a manner that is inconsistent with the manufacturer's printed information. Insure that all employees installing the Clutcher System have been properly trained on the use of this product.



DUCTMATE®
Industries, Inc.

DESCRIPTION

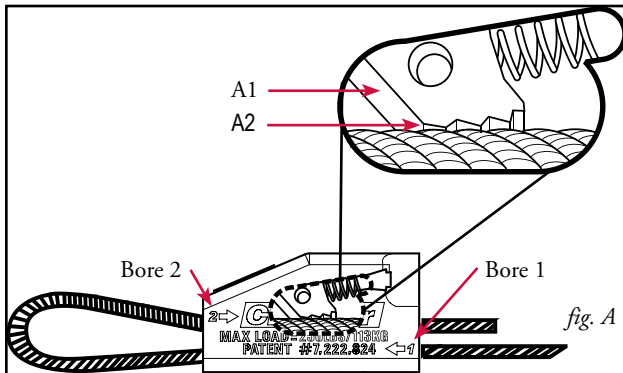

The Ductmate Clutcher System is a complete Steel Cable hanging system for HVAC Systems.

The Ductmate Clutcher Cable Hanging System consists of Ductmate Clutcher Cable and the Ductmate Clutcher mechanism. For the system to work properly, both components must be used. Ductmate Clutcher Cable is the only cable tested and approved for use with the Ductmate Clutcher system. Use of any other cable is prohibited, and will void the Ductmate warranty.

The Clutcher mechanism uses a serrated steel wedge to grip the Clutcher Cable (fig. A1). The housing of the mechanism is cast out of metal. The shape and orientation of the wedge allows Clutcher Cable to pass through in one direction. When a load is applied to the Clutcher Cable in the opposite direction, the wedge grips the Clutcher Cable and presses it against the Clutcher mechanism housing, preventing it from moving (fig. A2).

The Clutcher mechanism has two bores or passages. The first bore allows the Clutcher Cable to pass freely through the housing; the second bore contains the wedge mechanism described above.

BASIC USE

Labor-saving, versatile means for the suspension of static load HVAC Systems.

SPECIAL CHARACTERISTICS

- Meets SMACNA upper and lower attachment construction standards if used per manufacturer's installation guidelines
- Seismic tested and conforms to ICC Code guidelines EG284
- Engineered for strength and durability
- Tapered bore design for fast and easy installation
- Eliminates the need to stock multiple lengths of cable
- Compact design is aesthetically pleasing
- Easily adjust hanging height by hand
- Available in 3 sizes to meet specific load ranges
- Items can be hung at angles up to 60° from vertical
- Comprehensive Clutcher Hanging System Load Charts available online at Ductmate.com

TECHNICAL INFORMATION

Clutcher Mechanism

HOUSING: Zinc Cast

SPRING: Steel

WEDGE: Hardened Steel

END CAP: Zinc

Clutcher Cable

This system requires that Ductmate Clutcher Cable be used to meet testing and product specifications.

SAFETY

The Clutcher system has been engineered and tested to meet SMACNA upper and lower attachment safety standards. The vertical load limit of the system is the maximum amount that can be supported. When designing a system, do not exceed the load limit of the Clutcher system.

VERTICAL LOAD LIMITS

Clutcher System	Maximum Load	Required Clutcher Cable
CL10	125 lbs. (56.7 kg)	WR10
CL20	250 lbs. (113.4 kg)	WR20
CL30	650 lbs. (294.8 kg)	WR30

The Ductmate Clutcher System and Ductmate Clutcher Cable must always be used in conjunction. Use of any other steel cable is prohibited.

PACKAGING INFORMATION

Size	Box Quantity	Bag Quantity	Bag/Boxes
CL10	500	10	50
CL20	400	10	40
CL30	120	4	30

CAUTION

- Never exceed the WORKING LOAD LIMIT. In calculating working load, the full weight of the duct with contents, controls, and accessories must be calculated.
- Loads should be carried evenly across all hanging points.
- Always check that the locking mechanism is fully engaged.
- Do not use the Clutcher hanging system for lifting.
- Do not apply paint, lubricants or other coatings to the Clutcher system.
- Advise owner and other contractors and post other notices as necessary to insure that paint, lubricants or other coatings are not applied in the future.
- Do not use in corrosive or extremely humid conditions. Such conditions, over time, can cause metal components to corrode and fail.
- Use only with static loads. Not intended for use with oscillating loads.
- Prior to use, store product in a clean, dry and safe condition.
- Care should be taken that sharp edges or thin wall duct do not come in contact with the system and abrade or damage the Clutcher Cable.
- When adjusting or disconnecting Clutcher system, always make sure that load is fully supported by other means.
- Be sure building structure is capable of supporting the weight of the load.
- Use appropriate hanging method to prevent lateral movement in suspended duct.
- Do not use the Standard Loop Configuration with duct over 18" in diameter.
- Do not use the Standard Loop or Single Point Saddle Configuration with rectangular duct.
- Do not stand or walk on duct system.
- When used as a supplementary support, object being suspended cannot exceed maximum load rating of the Clutcher system.
- For extreme temperature ranges consult design engineer.
- Do not reuse cable once when Clutcher mechanism has been disengaged.
- Reference Clutcher Duct Construction Standards.

ASSEMBLY EXAMPLES

ROUND OR OVAL DUCT

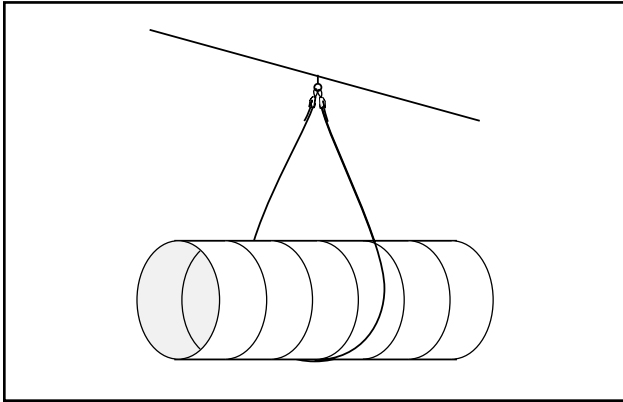

RECTANGULAR DUCT

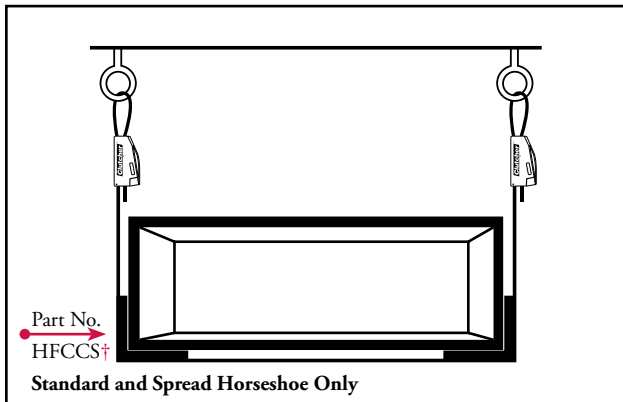

SIDE LOADINGS

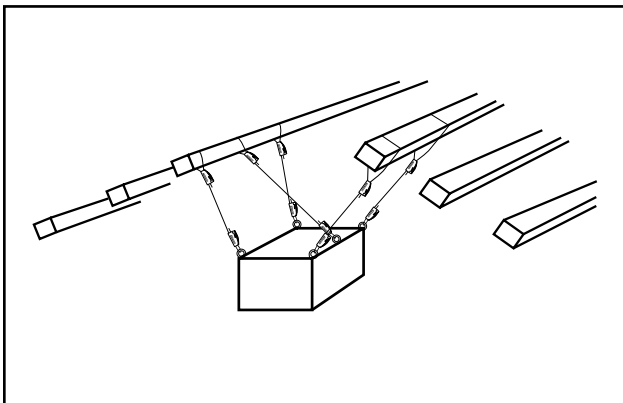

CLUTCHER MECHANISM DIRECTIONS

Attaching the Clutch mechanism to the Clutch Cable is quick and easy. Insert the Clutch Cable through the free bore side, starting on the wider end of the Clutch mechanism. Loop the Clutch Cable around the upper attachment point, and into the wedge side of the Clutch mechanism on the narrower end. There are arrows cast into the Clutch mechanism body that indicate which way to insert the Clutch Cable. At least 3" (76.2mm) of Clutch Cable should be extending out of the Clutch mechanism housing. Repeat the process with a second Clutch unit to cradle the load.

* Tip: When cutting Clutch Cable, use a quality cutter designed for Clutch Cable. Tin snips, diagonal cutters, and electrical cable cutters will not work; they will fray the ends of the Clutch Cable and prevent it from sliding into the Clutch mechanism correctly.

Step 1



Step 2



Step 3



Step 4



Step 5

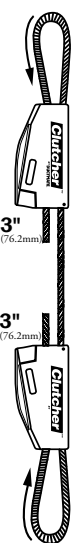

A 3" (76.2mm) minimum length of cable must be left protruding from the locking mechanism.

WARNING

DO NOT attempt to use the Clutch mechanism to splice two cables together, or attempt to secure the Clutch Cable via only one bore in the Clutch mechanism. The same Clutch Cable must pass through both bores in the Clutch mechanism.

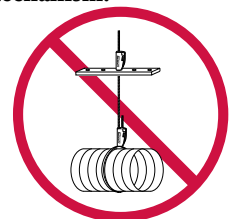
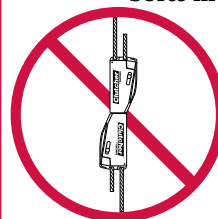

INSTALLATION INSTRUCTIONS

After the ductwork is leveled and the connection at the upper attachment secured with the Ductmate Clutcher Cable, then proceed with attaching the Clutcher mechanism to the object being suspended.



1. Insert Clutcher Cable through free flowing side of Clutcher mechanism.

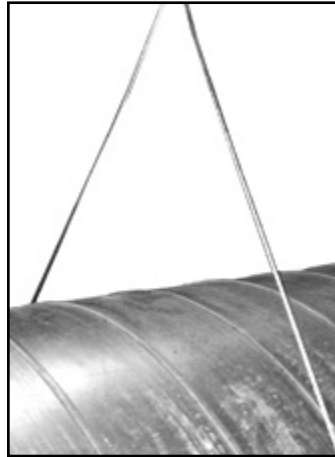

3. Wrap cable around object being suspended (round duct in the case).

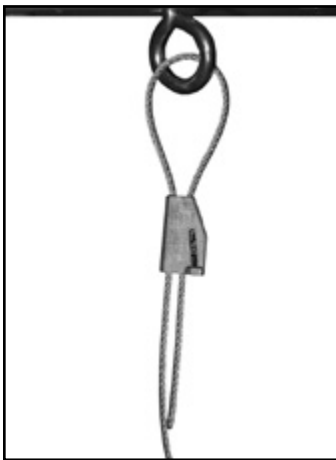

2. Loop cable through eye bolt and into locking mechanism of Clutcher

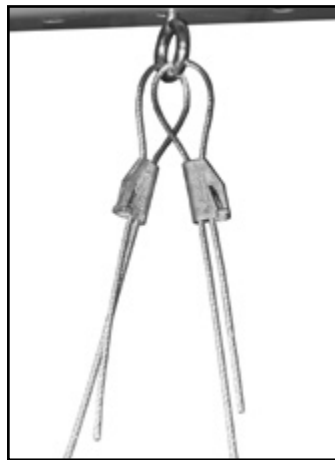

4. Loop cable through the same eye bolt as in step 2 and secure with a second Clutcher using same method as step 1 and 2

WARNING - Before Installation Is Completed

Make sure the load is evenly distributed over ALL Clutcher mechanisms and that ALL Clutcher mechanisms are engaged.

LIMITED PRODUCT WARRANTY

Ductmate warrants that Clutcher, when properly installed and maintained, will be free from defects in material and workmanship, and will comply with all written specifications made by Ductmate at the time of sale. Ductmate's warranty shall run for a period of one year from the date of manufacture.

Warranty Limitation

The warranty stated above is in lieu of all other warranties, express or implied, including but not limited to the implied warranties of MERCHANTABILITY AND FITNESS FOR A PARTICULAR PURPOSE. Although Ductmate may have suggested the product, or provided written or oral advice to the Purchaser, it is the Purchaser's responsibility to test and determine the suitability of Clutcher, for the intended use and purpose, and Purchaser and/or its customer assumes all risk and liability whatsoever regarding such suitability.

Limitation of Liability

In the event of a breach of the above warranty, Ductmate's sole obligation, and Purchaser's sole and exclusive remedy, shall be, at Ductmate's option, repair or replacement of any defective products, or refund of an applicable portion of the purchase price. Ductmate shall have no liability for costs of removal or reinstallation of the product. The Purchaser agrees that no other remedy, including but not limited to loss of profits, loss sales, injury to person or property, or any other special, incidental or consequential damages, shall be available to the Purchaser for any claim arising out of this Agreement, regardless of whether such claim is made in contract or in tort, including strict liability in tort. In no event will Ductmate be obligated to pay damages to the Purchaser in any amount exceeding the purchase price that the Purchaser paid to Ductmate for the allegedly defective product.

HANGING CONFIGURATIONS

The type of hanging configuration used depends on the application. The following hanging configurations apply to round or oval ductwork only. For rectangular ductwork, use Standard or Spread Horseshoe configuration. It is up to the end user to determine the best configuration for their particular installation.

The first method is called the single point saddle method (fig. 1). This method is to be the primary hanging method when using the Clutcher mechanism. The Clutcher Cable is looped through an eye bolt that is attached to the top support and then secured with a Clutcher. The same cable is then looped around the duct and back through the same eye bolt, then secured with a second Clutcher. This method ensures that the working load limit of the Clutcher is not adversely affected when larger duct is used.

The second method is the standard horseshoe (fig. 2). In this method, the Clutcher Cable is looped around the upper support and secured with a Clutcher mechanism, then routed under the ductwork and back up to the upper support to be secured with another Clutcher mechanism. This method helps to eliminate some swinging in the ductwork. Using two Clutcher mechanisms on a single cable at separate attachment points, does not change the maximum stated load rating. When supported in this fashion, the tension in the Clutcher Cable is reduced by half. This mechanical advantage is the same concept that makes a block and tackle work. This configuration can be used for general purpose hanging when an increased factor of safety is desired.

Next is the spread horseshoe method (fig. 3). This is the same layout as above, but the Clutcher Cables are spread to the side, creating a measure of cross bracing. Since the Clutcher Cables are on an angle in this method, there is a reduction in their working load limit. This configuration can be used when additional stability is desired. Items can be hung at angles up to 60° from vertical.

We'll call the last method the standard loop (fig. 4). The Clutcher Cable is looped around the upper support and secured with a Clutcher mechanism, then looped around the duct and secured with another Clutcher mechanism. The advantage of this method is its simplicity. It is suitable for applications where the duct will not experience lateral forces or be prone to swinging. An example of this would be a duct that is attached to a wall or other fixed element on each end. This configuration can be used for general purpose hanging. **The standard loop is only permitted for use on round duct diameters 18" or less, and on oval duct with a major axis of 18" or less.**

HANGING ON AN ANGLE

When using the spread horseshoe method, the tension in the Clutcher Cable increases. Table 1 shows the reduced working load limits for each size of Clutcher mechanism, determined by the angle in the Clutcher Cable.

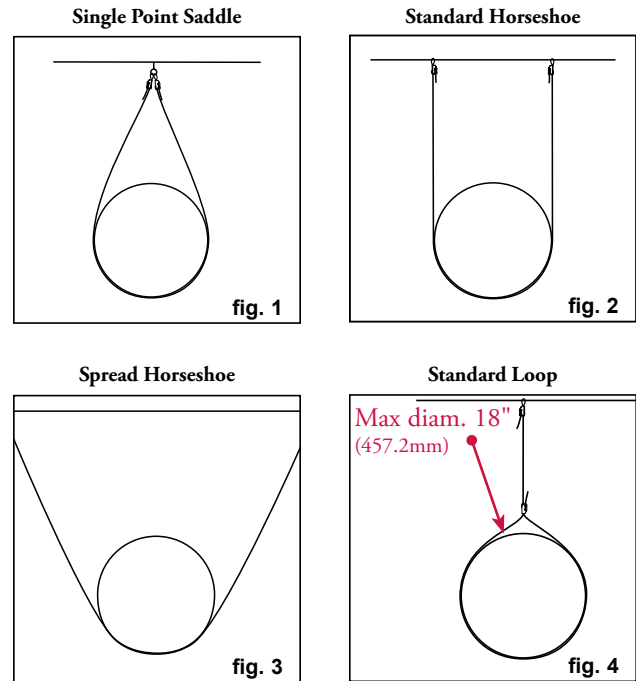

MAXIMUM LOADS FOR NON-VERTICAL SUPPORT

(Table 1: Load Limits) *

Angles from Vertical (in degrees)	Maximum Load for Clutcher Mechanism		
	CL10	CL20	CL30
0	125.0 lbs (56.7 kg)	250.0 lbs (113.4 kg)	650.0 lbs (294.8 kg)
5	124.5 lbs (56.5 kg)	249.0 lbs (112.9 kg)	647.5 lbs (293.7 kg)
10	123.1 lbs (55.8 kg)	246.2 lbs (111.7 kg)	640.1 lbs (290.3 kg)
15	120.7 lbs (54.7 kg)	241.5 lbs (109.5 kg)	627.9 lbs (284.8 kg)
20	117.5 lbs (53.3 kg)	234.9 lbs (106.6 kg)	610.8 lbs (277.1 kg)
25	113.3 lbs (51.4 kg)	226.6 lbs (102.8 kg)	589.1 lbs (267.2 kg)
30	108.3 lbs (49.1 kg)	216.5 lbs (98.2 kg)	562.9 lbs (255.3 kg)
35	102.4 lbs (46.4 kg)	204.8 lbs (92.9 kg)	532.4 lbs (241.5 kg)
40	95.8 lbs (43.5 kg)	191.5 lbs (86.9 kg)	497.9 lbs (225.8 kg)
45	88.4 lbs (40.1 kg)	176.8 lbs (80.2 kg)	459.6 lbs (208.5 kg)
50	80.3 lbs (36.4 kg)	160.7 lbs (72.9 kg)	417.8 lbs (189.5 kg)
55	71.7 lbs (32.5 kg)	143.4 lbs (65.0 kg)	372.8 lbs (169.1 kg)
60	62.5 lbs (28.4 kg)	125.0 lbs (56.7 kg)	325.0 lbs (147.4 kg)

Comprehensive Load Charts and Installation Videos available online at ductmate.com

STABILITY IN THE DUCT SYSTEM

When installed, the duct system should be stable enough that it doesn't swing or move when in use. Excessive movement can lead to fatigue failures in the joints or connections.

Typically, a duct run will be attached to some rigid object, such as a wall or equipment at one or both ends of the run.

When a run of duct is anchored only at one end, and cantilevered outward, the free end of the run can be expected to swing laterally (fig. 5a). When a long run of duct is anchored at both ends, the free center of the duct run may swing laterally (fig. 5b). If two sections of duct anchored at one end converge at a 90° angle (fig. 5c), free sections of duct may swing laterally.

In an application where movement is not expected, the single point saddle method (fig. 1), the standard horseshoe method (fig. 2), and the standard loop (fig. 4) can be used. When lateral movement needs to be minimized, the spread horseshoe (fig. 3) should be used.

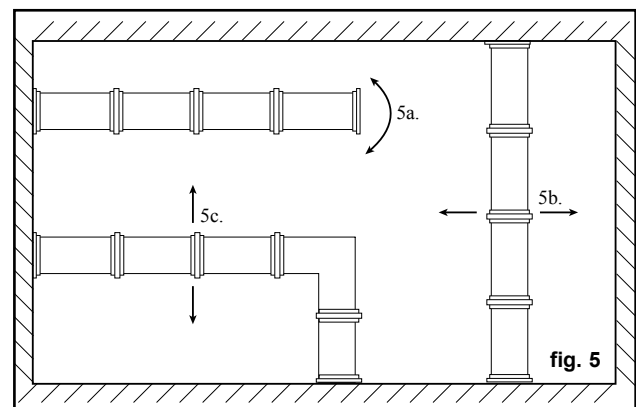

CLUTCHER CABLE

7x7

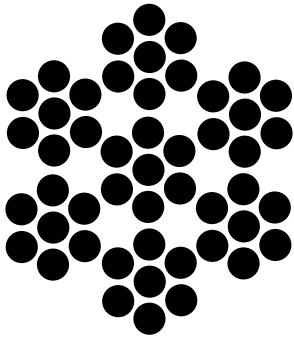

7x19

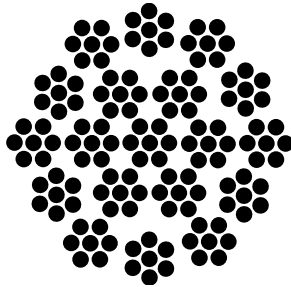

DESCRIPTION

Aircraft quality zinc coated Clutcher Cable available in 7 x 7 or 7 x 19 thread types.

BASIC USE

Ductmate Clutcher Cable is designed for the suspension of HVAC systems. The Ductmate Clutcher System and Ductmate Clutcher Cable Must Always be Used In Conjunction. Use Of Any Other Steel Cable Is Prohibited.

SPECIAL CHARACTERISTICS

- Ductmate Clutcher Cable can be easily recognized by the unique red thread woven into the cable
- Engineered for superior strength
- Supplied in spools of 500' and 1,000' to reduce waste
- Available in 3 diameter sizes to match each Clutcher mechanism

PACKAGING INFORMATION - 7 X 7

Part Number	Length	For Use With
WR10500	500' Spool	CL10
WR101000	1,000' Spool	CL10
WR20500	500' Spool	CL20
WR201000	1,000' Spool	CL20

PACKAGING INFORMATION - 7 X 19

Part Number	Length	For Use With
WR30500	500' Spool	CL30
WR301000	1,000' Spool	CL30

WARNING

When adjusting a Clutcher mechanism, be sure that the load is supported by alternate means before pulling back on the wedge and releasing the Clutcher Cable.



Charleroi, PA

210 Fifth Street
Charleroi, PA 15022
800-245-3188
724-258-0500
FAX: 724-258-5494

Lodi, CA

810 S. Cluff Avenue
Lodi, CA 95240-9141
800-344-3270
209-333-4680
FAX: 209-333-4678

www.ductmate.com



Distributed By:

Ductmate is a proud member of the following organizations:



© Copyright Ductmate Industries, Inc. All rights reserved.

347-05/16